

Item number: **MSS.22.995.10000/B**

Revision: **00** · Date: **01 - 2023**

Engine guard

 ~ 1.5 h.

EASY  DIFFICULT

ENGLISH · Thank you for choosing this premium product from SW-MOTECH. Visit our online shop for more information (e.g. model assignments). Required documents (e.g. general certification) are available there for you to download. **Please read and understand all the instructions, safety information and warnings in these mounting instructions before mounting and using the product in order to avoid injury and damage. Keep these mounting instructions for reference.**

This product was developed for vehicles in factory condition. Compatibility with original accessories or accessories from other manufacturers cannot be guaranteed.

These mounting instructions have been prepared to the best of our current knowledge. No legal claims relating to accuracy can be made. Errors and omissions excepted. We reserve the right to make technical and design changes. The copyright is held by SW-MOTECH.

SAFETY WARNING SYMBOL

 This warning symbol is used in these mounting instructions to warn of deadly dangers, injuries or other hazards. The words **DANGER**, **WARNING** or **CAUTION** are used as part of this warning symbol to convey important safety messages and information relating to the installation and use of this product. These words, together with the safety warning symbol, mean:

▲ DANGER: Indicates a hazardous situation which, if not avoided, will result in death or serious injury!

▲ WARNING: Indicates a hazardous situation which, if not avoided, may result in death or serious injury!

▲ CAUTION: Indicates a hazardous situation which, if not avoided, may result in minor or moderate injury!

△ NOTE: Important information, but not relating to a risk of death or injury (property damage only)!

GENERAL INFORMATION

▲ WARNING: Assembly and/or maintenance of this product requires advanced technical skills, appropriate tools and a good understanding of tool usage and torque specifications. For your own safety, SW-MOTECH recommends that assembly and/or maintenance is carried out by a qualified and certified two-wheeler workshop.

▲ WARNING: If you decide to install this product yourself, read the installation instructions carefully and fully before installation and use, and follow all instructions to avoid serious or fatal injuries. Also observe all relevant information in the vehicle manual when mounting and using the product. **IF YOU DO NOT UNDERSTAND ANY PART OF THESE MOUNTING INSTRUCTIONS OR REQUIRE EXPLANATION OF ANY INSTRUCTION, DO NOT ATTEMPT TO INSTALL THIS PRODUCT WITHOUT ASKING SW-MOTECH FOR HELP!**

PREPARATION: Read the mounting instructions carefully and make sure that all parts on the parts list are available.

▲ CAUTION: Ensure that your vehicle is standing securely. Switch off the engine and remove the ignition key. Allow the engine/exhaust to cool down, if necessary. Disconnect the battery when working on the electrics. Only use suitable tools, and always wear protective goggles and gloves during assembly and maintenance. Have a second person help you during assembly and maintenance.

ASSEMBLY: All parts and connections removed from the vehicle must be reinstalled according to the vehicle manufacturer's specifications or replaced with parts and hardware supplied by SW-MOTECH.

▲ WARNING: Secure all threads with a medium-strength liquid threadlocker, unless otherwise specified.

▲ DANGER: Tightening torques not defined by SW-MOTECH must be obtained from the vehicle manufacturer or a certified motorbike workshop.

FUNCTIONALITY CHECK: After assembly, make sure that no moving parts are obstructed and that the function of the vehicle is not impeded. Cables and hoses must not be chafed and/or pinched.

▲ WARNING: Carry out a comprehensive functionality check before you start to drive. Check the tightening torque of all connections and the tight fit of the product after the first 50 km and then at regular intervals. Mounted accessories can change the handling and stability of the vehicle.



SW-MOTECH GmbH & Co. KG
Ernteweg 7-10
35282 Rauschenberg
Germany



info@sw-motech.com
www.sw-motech.com

LEGEND OVERVIEW - READ AND KEEP MOUNTING INSTRUCTIONS!



Take note of the symbols and what they mean in the ASSEMBLY section. If the term OEM appears in the ASSEMBLY section, the vehicle manufacturer's specifications must be observed and applied.



If you have any questions, please don't hesitate to contact our Customer Service team or our distributors. You can find our telephone number and a list of our distributors in our online shop:

www.sw-motech.com



Tighten/note the tightening torque information:

Indicates the tightening torque of a part specified by SW-MOTECH or the vehicle manufacturer (OEM).



Do not use thread lock: Indicates that no liquid thread lock should be used at this point.



Use thread locker: Indicates that a thread must be coated with liquid thread locker. H (HIGH): high strength; M (MEDIUM): medium strength; L (LOW): low strength.

PARTS LIST - READ AND KEEP MOUNTING INSTRUCTIONS!

<p>4</p>	<p>1</p>  <p>MSS.22.995.900.01.02</p> <p> 1/1</p>	<p>2</p>  <p>GT.0120.0100.0088.0040</p> <p> 5/5</p>	<p>3</p>  <p>Ø 10 / ø 8.4 / h 8.8</p> <p>DB.ST.100.084.088.01</p> <p> 5/5</p>			
<p>5</p>	<p>4</p>  <p>MSS.22.995.005.11</p> <p> 1/1</p>	<p>5</p>  <p>MSS.22.995.003.11</p> <p> 1/1</p>	<p>6</p>  <p>M12 x 335; DIN 6921</p> <p>SC.ST.12.335.01.6921F.109</p> <p> 1/1</p>	<p>7</p>  <p>Ø 20 / ø 12.5 / h 45</p> <p>DB.ST.200.125.045.01</p> <p> 2/2</p>	<p>8</p>  <p>Ø 20 / ø 12.5 / h 5</p> <p>DB.00.200.125.005.01</p> <p> 1/1</p>	
<p>6</p>	<p>9</p>  <p>MSS.22.995.004.11</p> <p> 1/1</p>	<p>10</p>  <p>M12 x 40; DIN 912</p> <p>SC.ST.12.040.01.912.088</p> <p> 1/1</p>	<p>11</p>  <p>M12 x 50; DIN 912</p> <p>SC.ST.12.050.01.912.088</p> <p> 1/1</p>	<p>12</p>  <p>ø 13; DIN 125</p> <p>US.ST.130.01.125</p> <p> 1/1</p>	<p>13</p>  <p>Ø 25 / ø 12.5 / h 5.5</p> <p>DB.ST.250.125.0055.01</p> <p> 1/1</p>	<p>14</p>  <p>M12; DIN 6927</p> <p>MU.ST.12.02.6927.08</p> <p> 1/1</p>
<p>7</p>	<p>15</p>  <p>M5 x 14; DIN 912</p> <p>SC.ST.05.014.02.912.088</p> <p> 2/2</p>	<p>16</p>  <p>ø 5.3; DIN 9021</p> <p>US.ST.053.02.9021</p> <p> 2/2</p>	<p>17</p>  <p>MSS.22.995.002.11</p> <p> 1/1</p>	<p>18</p>  <p>M6 x 16; DIN 933</p> <p>SC.ST.06.016.01.933.088</p> <p> 2/2</p>	<p>19</p>  <p>ø 6.4; DIN 125</p> <p>US.ST.064.02.125</p> <p> 2/2</p>	
<p>7</p>	<p>20</p>  <p>M8 x 30; DIN 931</p> <p>SC.ST.08.030.01.931.088</p> <p> 3/3</p>	<p>21</p>  <p>ø 8.4; DIN 125</p> <p>US.ST.084.02.125</p> <p> 4/4</p>	<p>22</p>  <p>M8 x 25; ISO 7380</p> <p>SC.ST.08.025.02.7380.109</p> <p> 1/1</p>	<p>23</p>  <p>M8 x 30; ISO 7380</p> <p>SC.ST.08.030.02.7380.109</p> <p> 1/1</p>	<p>24</p>  <p>ø 8.4; DIN 9021</p> <p>US.ST.084.02.9021</p> <p> 4/4</p>	<p>25</p>  <p>M8; DIN 6927</p> <p>MU.ST.08.02.6927.08</p> <p> 4/4</p>

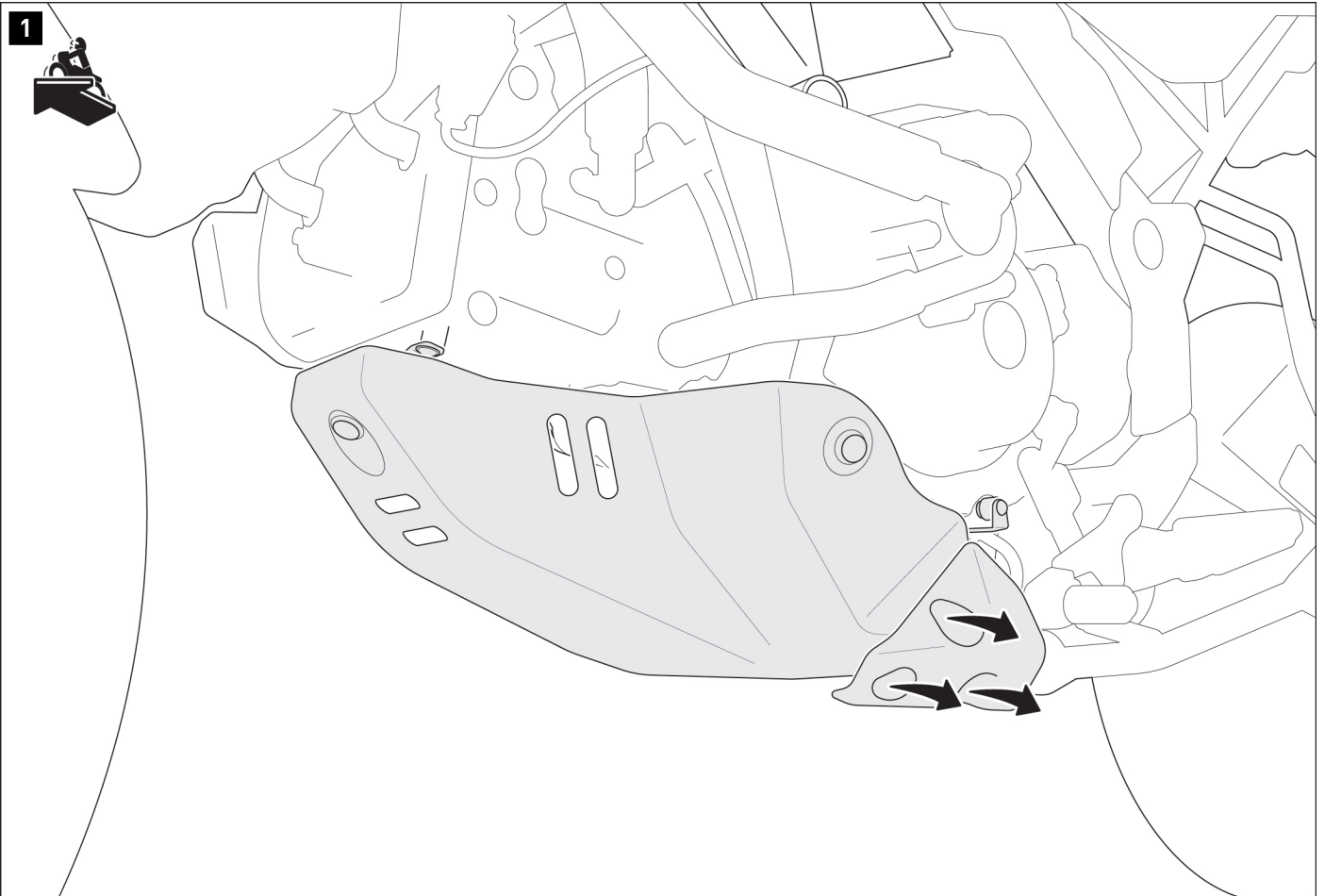

- ▲ **WARNING: Always wear eye and hand protection!**
- ▲ **WARNING: Always use the proper tools!**

Loosen the indicated screws on the plastic cover.
Remove the plastic cover from the vehicle.



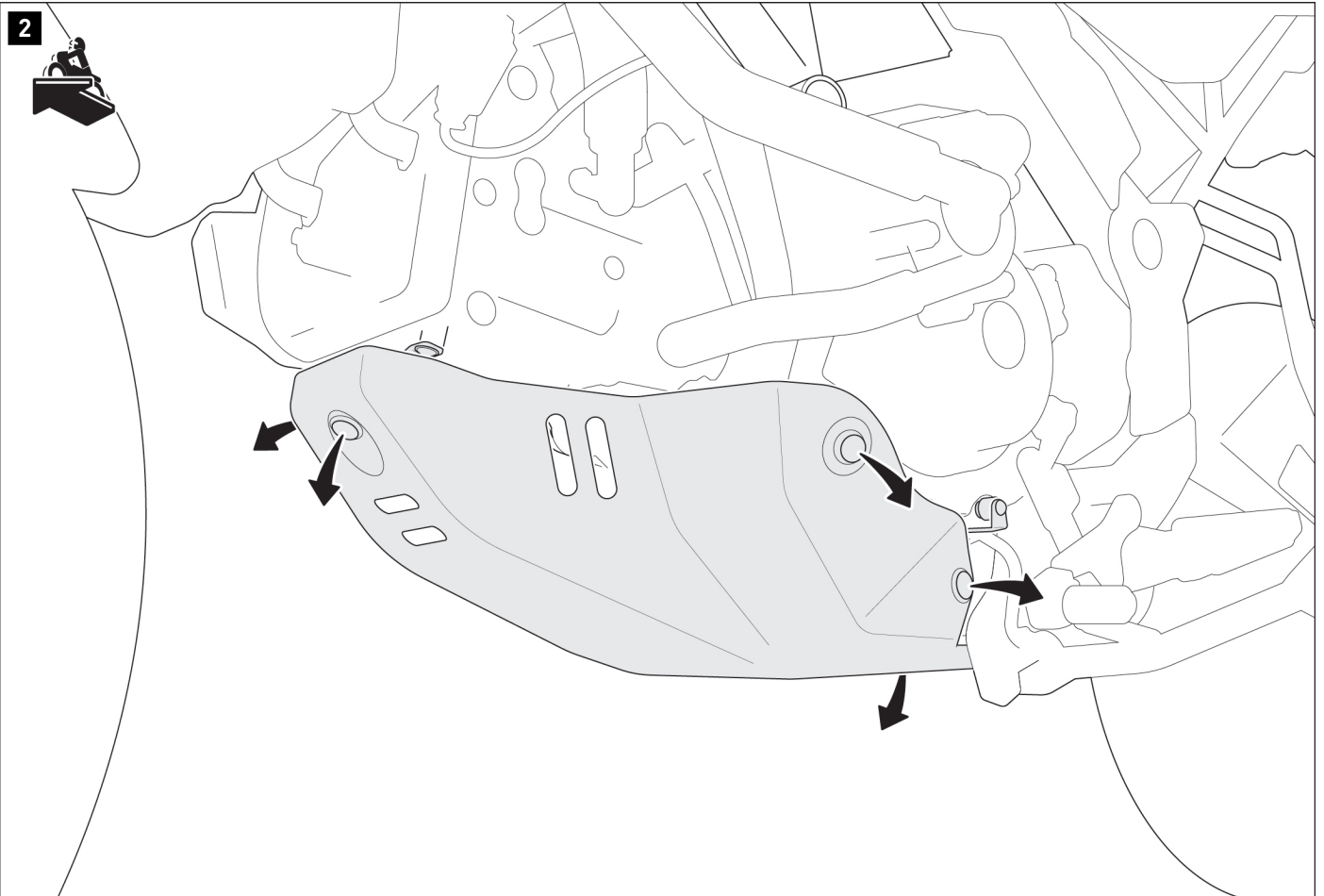

Loosen the indicated screws on the original engine guard.
Remove the engine guard from the vehicle.

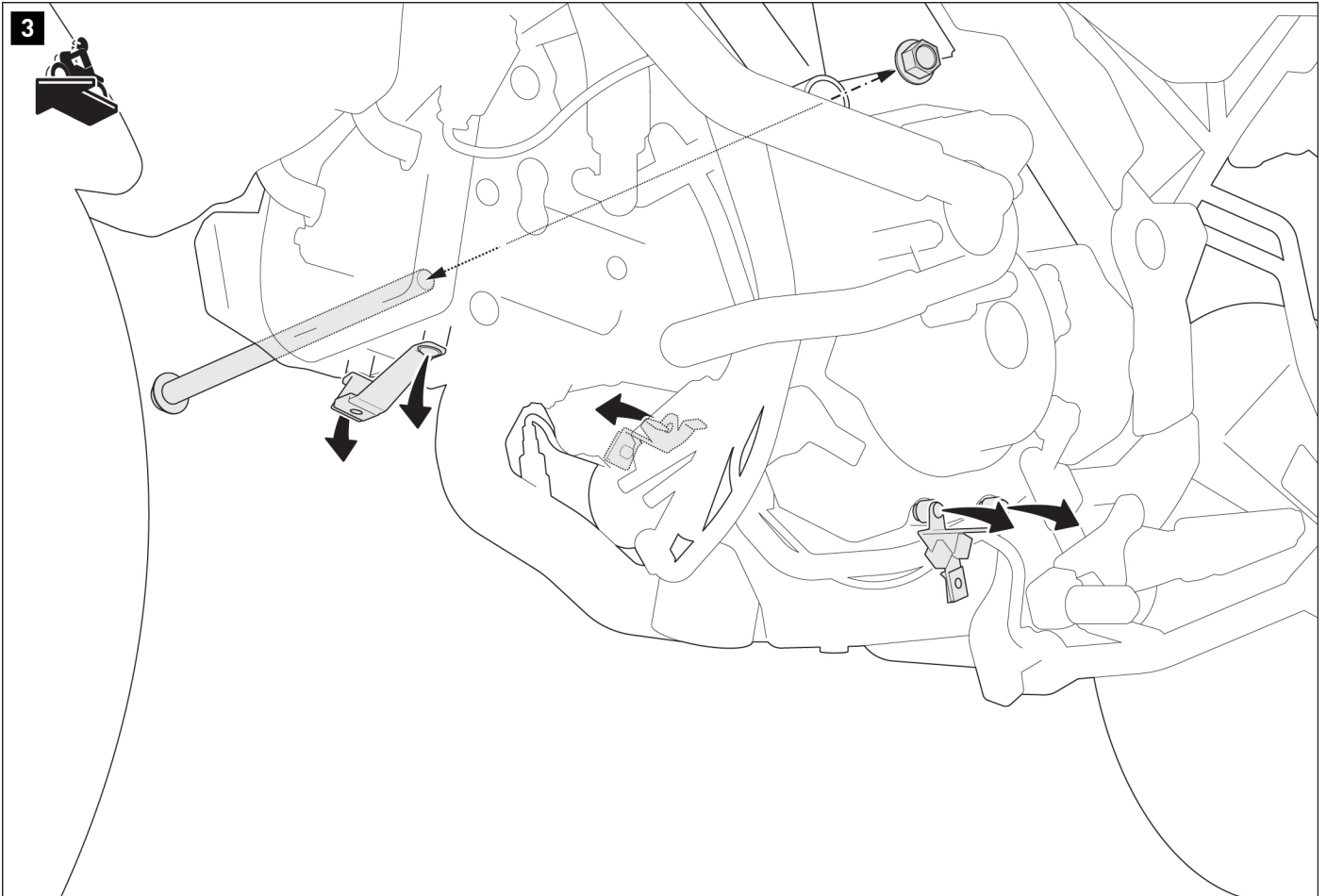

▲ WARNING: Ensure the engine is properly supported using a corresponding jack!

Loosen the engine bolt nut as indicated.
Remove the engine bolt from the vehicle.

Loosen the indicated screws on the retaining plates on both sides.
Loosen the cable tie on the left retaining plate.
Remove the retaining plates from the vehicle.

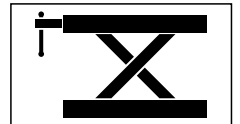

4

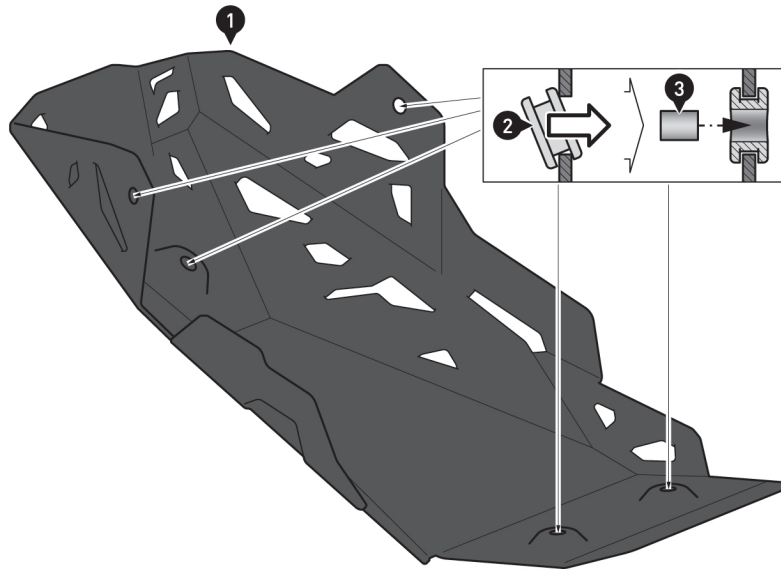

Insert the rubber grommets (2) into the openings of the engine guard (1).
Then press the spacers (3) into the openings of the rubber grommets (2).



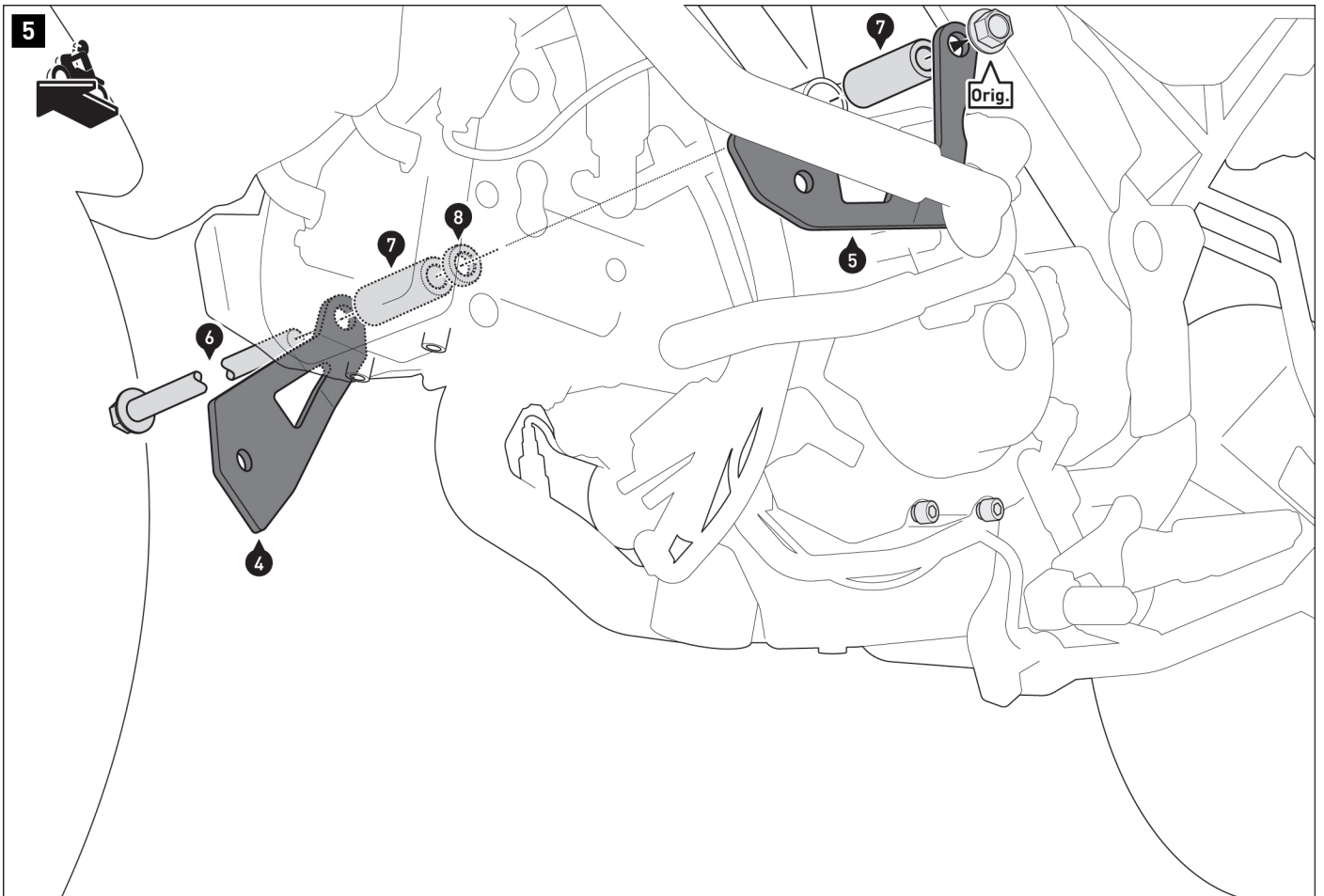

NOTE: Use the indicated parts when mounting the SW-MOTEC crash bar at the same time. The crash bars are screwed onto the mounting brackets (4) and (5).

Screw the mounting brackets (4) and (5) to the vehicle on both sides using the original nut (Orig.).
Do not tighten the screw yet.

Then remove the jack.

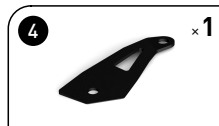

OEM

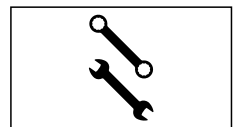
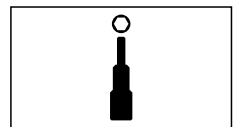

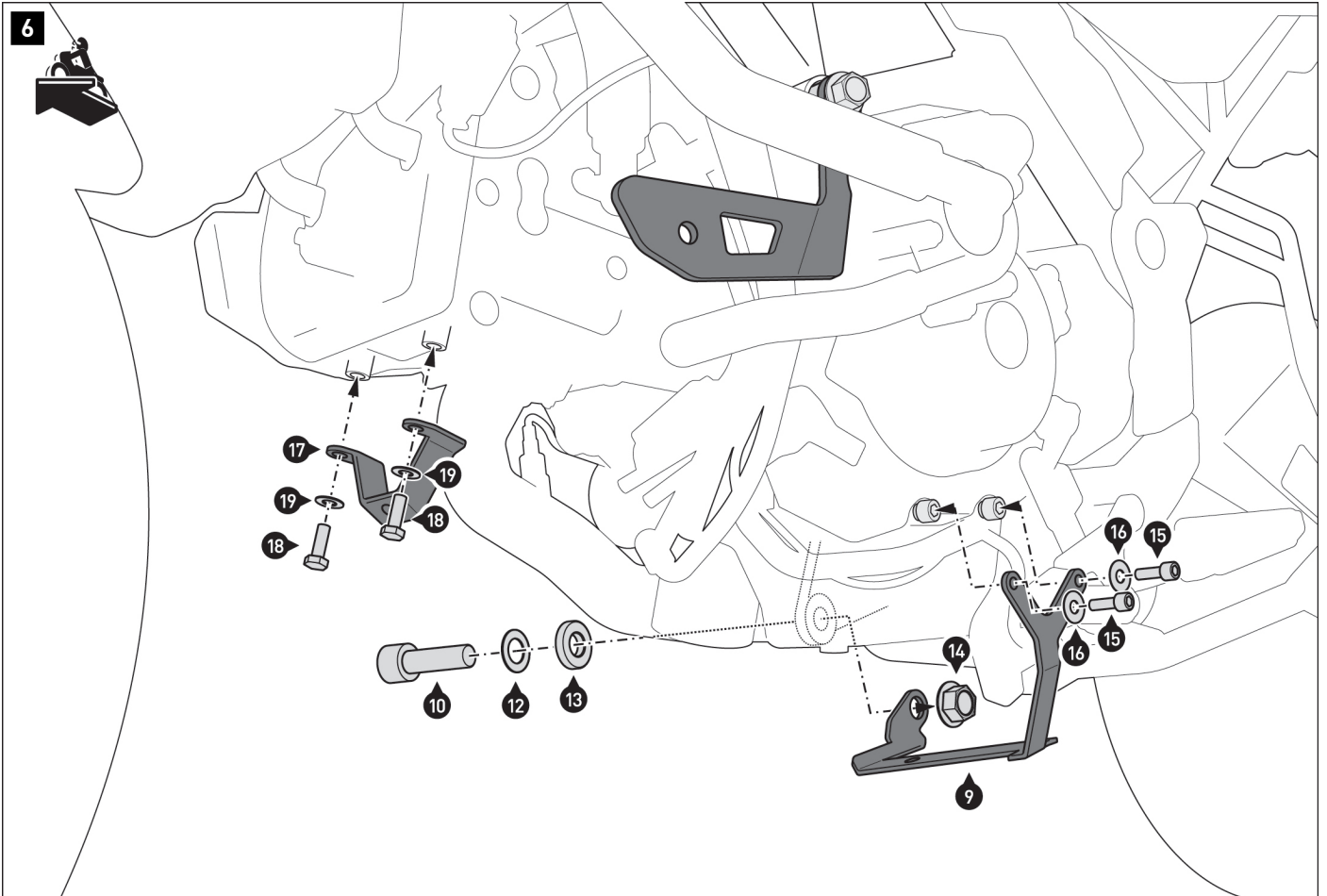

NOTE: Use the screw (11) at the left attachment point when mounting the SW-MOTECH centerstand at the same time. Parts (12) and (13) are omitted. Use the parts on the centerstand instead.

Screw the mounting brackets (9) and (17) to the vehicle.

WARNING: Use liquid thread locker (NOT on screws (10) and (11))! Do not tighten the screws yet.

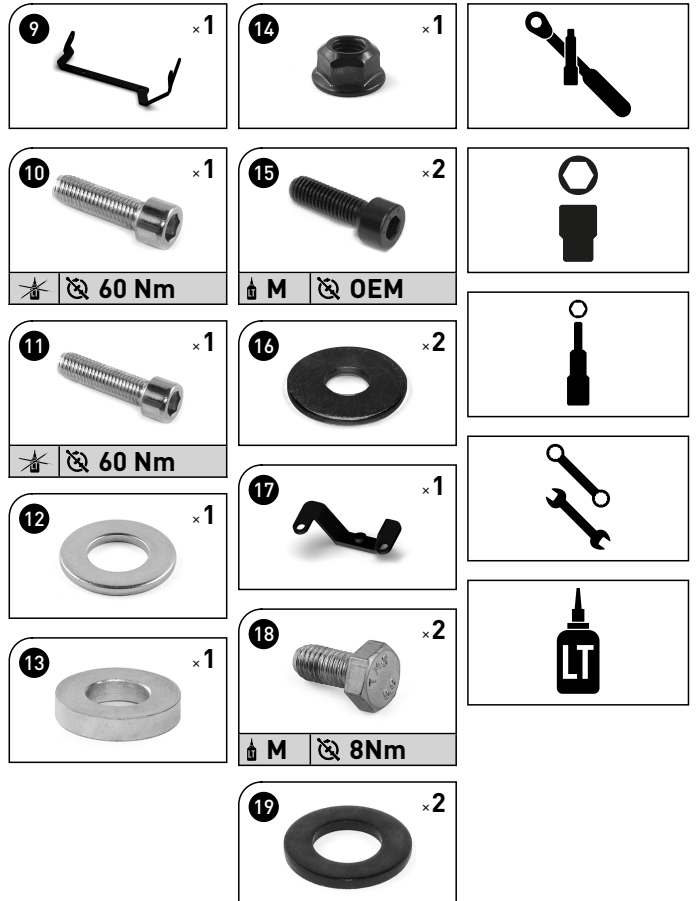



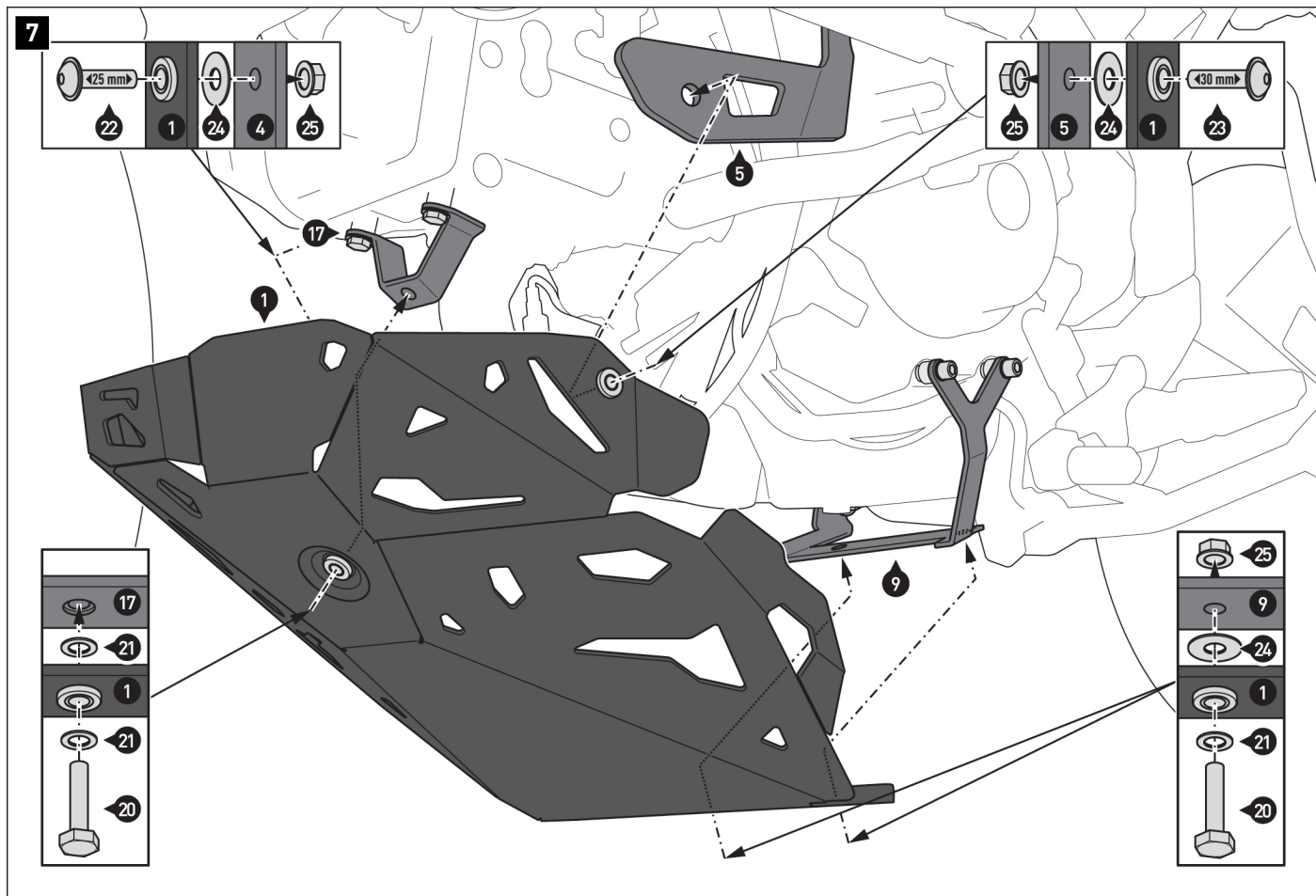









MOUNTING STEP - READ AND KEEP MOUNTING INSTRUCTIONS!



Screw the engine guard (1) to the mounting brackets (4), (5), (9) and (17).
⚠WARNING: Use liquid thread locker (front screw (20) only)!

When all components are loosely attached, tighten all screws as specified in the mounting instructions. Concealed screws can be tightened through the recesses in the engine guard.

 <p>20 x3</p> <p>18 Nm</p>	 <p>25 x4</p>	
 <p>21 x4</p>		
 <p>22 x1</p> <p>12 Nm</p>		
 <p>23 x1</p> <p>12 Nm</p>		
 <p>24 x4</p>		
		

PRODUCT-SPECIFIC NOTES

⚠ WARNING: Ground clearance may be restricted by this product! Particular caution is required when cornering at extreme inclination and/or driving on uneven ground (e.g. curbs and bumps)!

⚠ WARNING: Motorcycle exhaust pipes often have large geometric tolerances. Make sure that there is sufficient distance between all parts in the affected areas!

⚠ NOTE: *Please observe the country-specific regulations for the registration/operation of your vehicle or any applicable TÜV regulations. After installation, parts subject to registration should be entered in the vehicle documents by your test center.*